

# HX10E 1150X540 INOX

## STAINLESS STEEL ELECTRIC SCISSOR LIFT - IP65



### STAINLESS STEEL

The HX10E stainless steel scissor lift makes possible an easy and light lifting to a height of 800 mm thanks to the reliable electric motor and to the powerful GEL battery keeping the goods at the suitable height to collect/deposit the loads, reducing the operator's effort. Entirely built in stainless steel AISI 304 (including the pump and the hydraulic components) suitable to work in the aggressive and corrosive environments where the cleaning and the hygiene are the most required values and where there is serious problem of corrosion related to the use of corrosive acids and saline solutions.



### EQUIPPED FOR DEMANDING APPLICATIONS

IP65 protection, AISI 304 stainless steel electro polished, sealed waterproof bearings, polyamide bushings make HX10E INOX match the food industry regulations. It is the ideal and clean solution for the handling in the agrifood, chemical and pharmaceutical industries. It is corrosion-proof, maneuverable and ergonomic and it is built to withstand regular high-pressure cleaning and disinfection satisfying the strictest hygienic regulations.



### TILLER

The handle offers an ergonomic tiller and an electric switch for lifting and lowering operations. The tiller design ensures operator comfort on pushing operations.

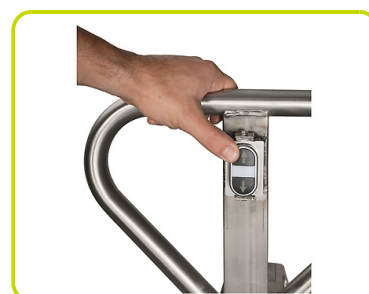

## REAR STABILIZERS

The control linkage makes possible the entry on the closed side of the pallet by a slight lifting, which facilitates the successive handling phases. Furthermore, machine stability is achieved by using load rollers in a more advanced position. Work is made stable and safe with the rear stabilizers, also when the working height exceeds the 400 mm and in the case of heavy loads.

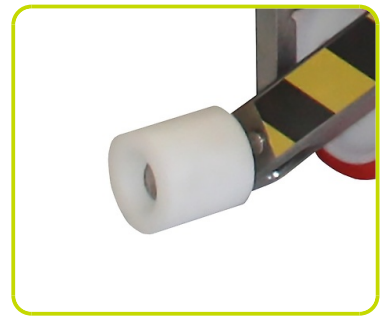

## SAFETY AND EFFICIENCY

The emergency pushbutton with function of battery cut-off switch (isolator) and the off-load valve allowing a smoother lowering of the load are some of the devices that make the work safer and more efficient.



## STANDARD EQUIPMENT

GEL 12V/75Ah battery: big size for long endurance also on low temperature environment, deep cycle gel is safe (no acid – vapor spilling out) and do not need maintenance.

ON-BOARD battery charger with extendable power charger cable.

Battery status indicator visible from the maneuvering station.



## EASY MAINTENANCE

Simple construction with a design that allows a really easy maintenance: the access to lifting motor, battery and charger can be done just removing few bolts and without lifting the unit.



## ADJUSTABLE FORK LOWERING SPEED

The machine is equipped with an adjustable valve that regulates the oil flow during the lowering operation. This means to have the possibility to regulate the lowering fork speed depending on the various application. Such adjustment can be easily done through the knob positioned inside the battery compartment.

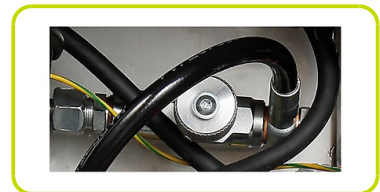

## CERTIFICATIONS

The design of HX10 INOX Scissor Lift makes the machine compliant to:  
UNI EN 1672-1: 2014 (product for alimentary business – basic concept)  
UNI EN 1672-2: 2009 (product for alimentary business – hygienic concept)



## OPTIONS

- Stainless steel AISI 316
- Tailor-made chassis to handle special loads
- Custom forks length and width



## Descrizione

1.3 Tipo di Propulsione		Manuale
1.4 Sistema di guida		Accompagnamento
1.5 Portata	Q Kg	1000
1.6 Baricentro	c mm	600
1.8 Distanza asse ruote di carico da base forca	x mm	155
1.9 Passo	y mm	1230

## Pesi

2.1 Massa in servizio	Kg	150
2.2 Carico asse posteriore (pieno carico)	Kg	610
2.2 Carico asse anteriore (pieno carico)	Kg	542
2.3 Carico asse anteriore (senza carico)	Kg	42
2.3 Carico asse posteriore (senza carico)	Kg	110

## Telaio/Ruote

3.2 Dimensione ruote anteriori - Larghezza	mm	85
3.2 Dimensione ruote anteriori - Diametro	mm	175
3.3 Dimensione ruote posteriori - Diametro	mm	82
3.3 Dimensione ruote posteriori - Larghezza	mm	90
3.5 Dimensioni ruote posteriori - Q.tà (x=motrice)	nr	2
3.5 Dimensioni ruote anteriori - Q.tà (x=motrice)	nr	2
3.6 Carreggiata anteriore	b10 mm	550
3.7 Carreggiata posteriore	b11 mm	550

## Dimensioni

4.4 Altezza di sollevamento	h3 mm	715
4.9 Altezza del timone in posizione di guida min	h14 mm	1190
4.15 Altezza forche abbassate	h13 mm	85
4.19 Lunghezza totale	l1 mm	1740
4.20 Lunghezza unità motrice	l2 mm	590
4.21 Larghezza totale	b1 mm	550
4.22 Dimensioni forche - Spessore	s mm	85
4.22 Dimensioni forche - Larghezza	e mm	170
4.22 Lunghezza forche	l mm	1150
4.25 Larghezza forche	b5 mm	550
4.32 Luce libera a metà passo	m2 mm	30
4.34 Corridoio di stivaggio per pallet 800x1200 longitudinalmente	Ast mm	1950
4.35 Raggio di volta	Wa mm	1345

## Motori elettrici

8.4 Rumorosità all'orecchio dell'operatore	dB(A)	67
--	-------	----

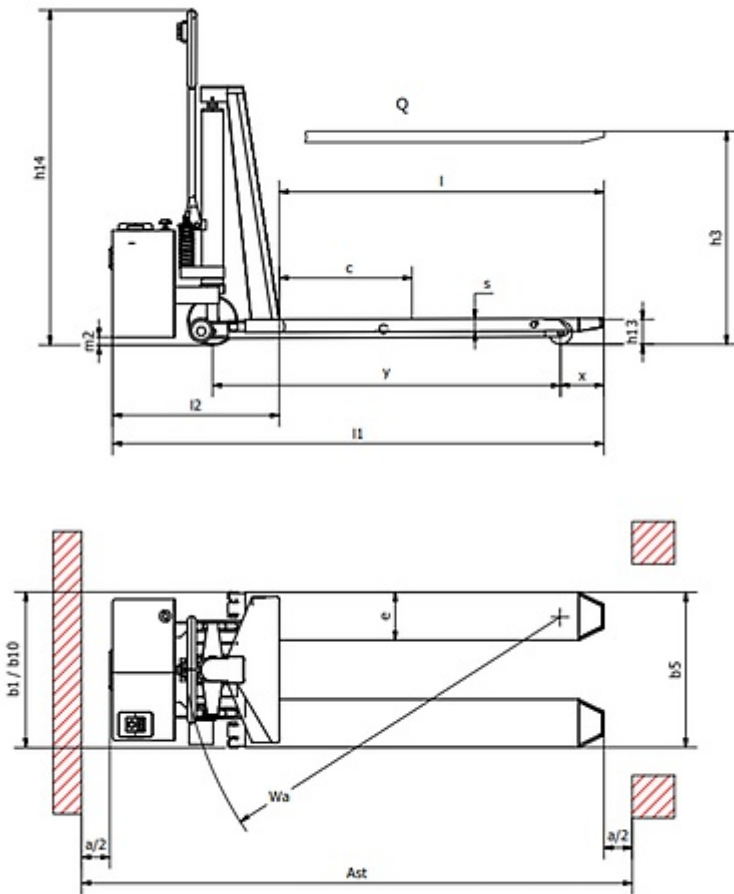

The information is aligned with the Data file at the time of download. Printed on 21/05/2020 (ID 11239)

©2019 | PR INDUSTRIAL s.r.l. | All rights reserved | Image shown may not reflect actual package. Specifications subject to change without notice

